

MSA/DMSB-002-RPS

REGISTRATION OF REAR PROTECTION SYSTEM

<i>Category</i>	Cadet
<i>Manufacturer</i>	KG sas
<i>Make</i>	KG
<i>Model</i>	TRIS
<i>Valid from</i>	10 January 2017
<i>Test report no. & issuing organisation</i>	CSI 0363\ME\PCA\16
<i>Number of pages</i>	4

This Homologation Form reproduces descriptions, illustrations and dimensions of the RPS at the moment of the MSA Registration. This document may be supplemented by official amendment. This document must be read in conjunction with the appropriate Class Regulations.



Photograph from front, above and side of RPS, including supports

SIGNATURE AND STAMP OF THE MSA

	<p>Date: 17 January 2017</p> <p>Signed by: Joe Hickerton</p> <p>Position: Technical Manager</p>
--	--

Any reproduction must be authorised by the MSA

Rear Protection System – Bodywork

Technical drawing (main external dimensions)

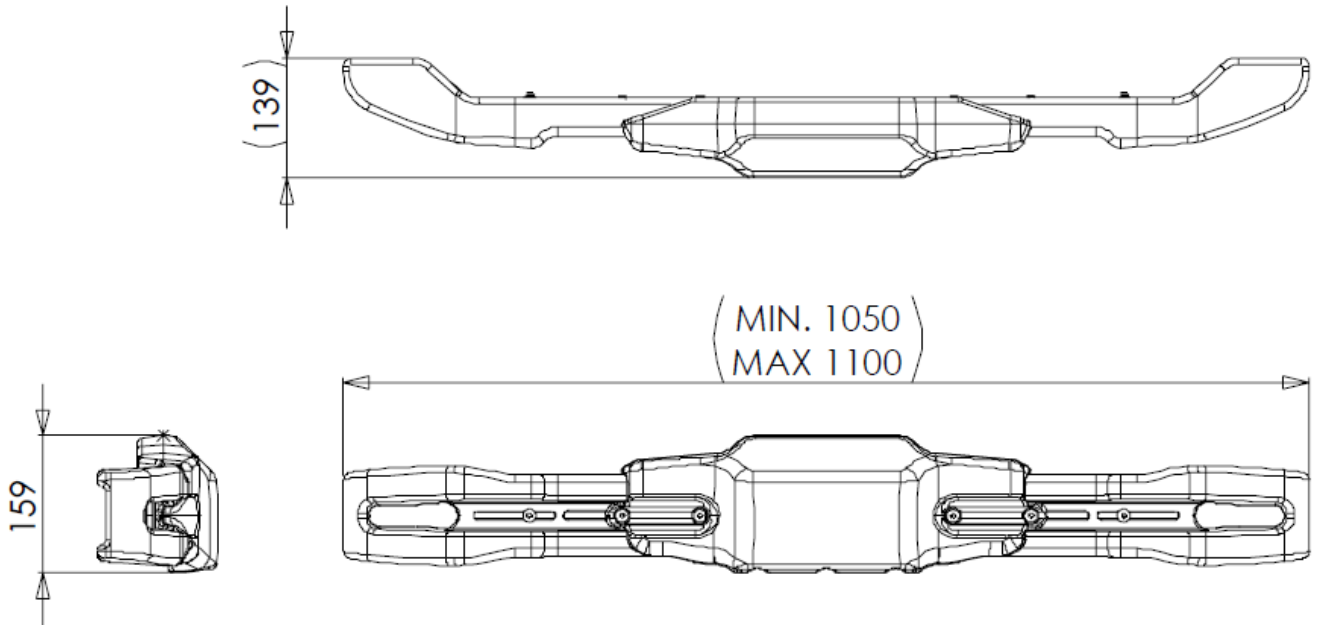

Mass in grams (bodywork only):	1200 g	± 10%
--------------------------------	--------	-------

Photo (bodywork only)



Rear Protection System – Attachment supports

Exploded technical drawing

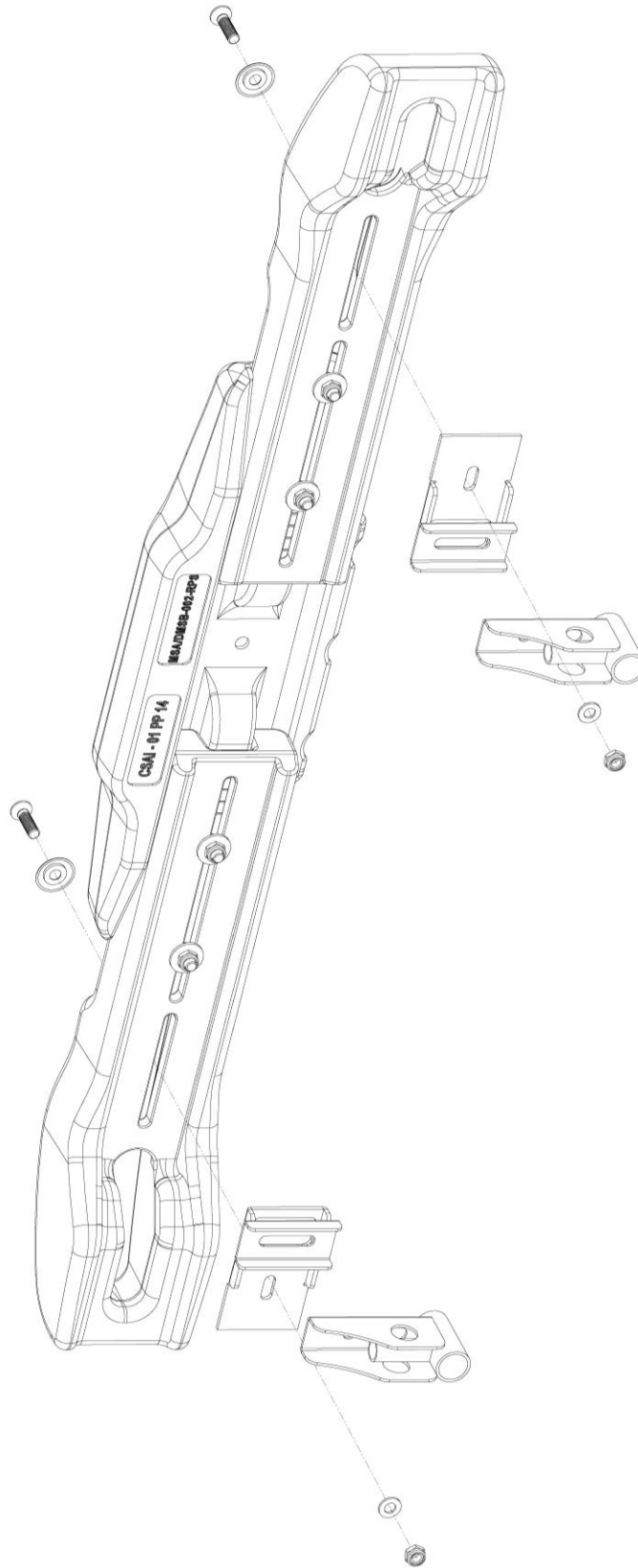

Mass in grams (attachments only):

815 g

± 5%

Registration No.

MSA/DMSB-002-RPS

Rear Protection System – Registration number marking

Marking must be clearly visible at all times

Photo of registration number marking – Bodywork



Temporary



Definitive

Photo of registration number marking – Attachment supports

